



Field-uplift testing

ASTM E907 and FM 1-52 tests continue to be problematic

June 2015

NRCA continues to receive a significant number of reports from roofing contractors, manufacturers and designers regarding the use of and problems associated with field-uplift tests as post-installation quality assurance measures for membrane roof systems. NRCA has addressed these testing issues a number of times during the years. Following is a summary of NRCA's previous discussions, as well as updated information and recommendations.

ASTM E907/FM 1-52

There are two recognized field test methods for determining adhered membrane roof systems' uplift resistances: ASTM E907, "Standard Test Method for Field Testing Uplift Resistance of Adhered Membrane Roofing Systems," and FM Global Loss Prevention Data Sheet 1-52 (FM 1-52), "Field Verification of Roof Wind Uplift Resistance."



An example of a test chamber used for negative-pressure uplift testing

Both test methods are similar and provide for affixing a 5- by 5-foot dome-like chamber to a roof surface's topside and applying a defined negative (uplift) pressure inside the chamber to the roof system's exterior-side surface using a vacuum pump (see photo). During the test, membrane surface deflection inside the chamber is visually monitored and measured to determine whether a roof system passes or is "suspect."

Using ASTM E907, a roof system is considered to be suspect if the deflection measured during the test is 25 mm (about 1 inch) or greater. During FM 1-52 testing, a roof system is suspect if the measured deflection is between $\frac{1}{4}$ of an inch and $\frac{1}{16}$ of an inch depending

on the maximum test pressure; 1 inch where a thin topping board (cover board) is used; or 2 inches where a thin cover board or flexible, mechanically attached insulation is used.

If an ASTM E907 or FM 1-52 test yields a suspect result, a test cut should be taken in the test area to determine whether failure has occurred and the specific failure mode.

ASTM E907 and FM 1-52 differ notably in their test cycles and maximum test pressures for determining roof system deflections and whether a roof system passes or is suspect. ASTM E907 testing is conducted in 15-pounds per square foot (psf) pressure intervals up to the calculated design wind (uplift) pressure for the specific roof system being evaluated. FM 1-52 testing is conducted using an initial 15-pounds psf pressure followed by 7.5-pound psf increments up to a maximum test pressure of 1.25 times the design uplift pressure for the specific roof system being evaluated.

Considering maximum test loading and allowable test deflections in combination, FM 1-52 requires 25 percent higher test loads, yet only allows as little as $\frac{1}{4}$ the test deflection of ASTM E907. That said, FM 1-52 is a significantly more stringent test than ASTM E907.

ASTM E907 originally was published as a recognized consensus standard in 1983, and it was revised in 1996. In 2013, ASTM withdrew ASTM E907 because a consensus could not be reached regarding necessary revisions—most significantly, defining the test method's precision and bias (accuracy). ASTM E907-96 still is available for use and can be obtained directly from ASTM's website, www.astm.org.

FM 1-52 is an FM Global-promulgated evaluation method and not a recognized industry-consensus test standard. FM 1-52's scope indicates it only is intended to confirm acceptable wind-uplift resistance on completed roof systems in hurricane-prone regions, where a partial blow-off has occurred or where inferior roof system construction is suspected or known to be present.

FM 1-52 originally was published by FM Global in October 1970. The negative-pressure uplift test was added in August 1980 and has been revised several times. The current edition is dated July 2012 and includes an option for "visual construction observation (VCO)" as an alternative to negative-pressure uplift testing. VCO provides for full-time, third-party monitoring of a roof system application to verify roof system installation in accordance with contract documents.

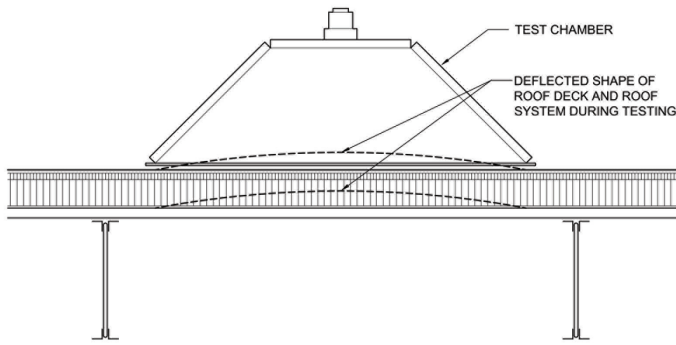

Figure 1: Illustration of a test chamber positioned between deck supports

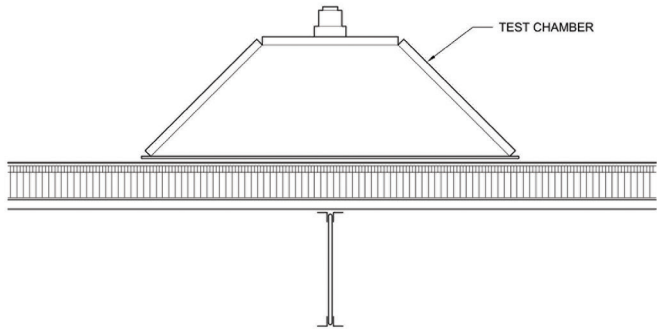

Figure 2: Illustration of a test chamber centered over a deck support

Test results' reliability

The reliability of the results derived from ASTM E907 and FM 1-52 is a concern, especially when the tests are used for quality-assurance purposes. A note in ASTM E907 acknowledges its test viability: "Deflection due to negative pressure will potentially vary at different locations because of varying stiffness of the roof system assembly. Stiffness of a roof system assembly including the deck is influenced by location of mechanical fasteners, the thickness of insulation, stiffness of decking, and by the type, proximity, and rigidity of connections between the decking and framing system."

For example, when testing an adhered roof system over a steel roof deck, placement of the test chamber relative to the deck supports (bar joists) can have a significant effect on tests results. If the test chamber is positioned between deck supports (see Figure 1), the test chamber's deflection gauge will measure roof assembly deflection at the deck's midspan at the point of maximum deck deflection. Also, in many instances, field-uplift testing results in steel roof deck overstress and deck deflections far in excess of design values, which can result in roof system failure. These situations can result in false suspect determinations of a roof system.

However, if the test chamber is placed centered over a deck support (see Figure 2), the influence of deck deflection is minimized.

Similarly, placement of the test chamber relative to insulation board edges, layout and mechanical fastener location or membrane lap seams significantly can affect results.

Also, movement from the test operator or other rooftop personnel can affect test results, making an otherwise acceptable test specimen suspect or vice versa. A statement in FM 1-52 acknowledges this issue: "... it is imperative that there be no walking near

the test area between the time the deflection gauge has been zeroed and the test is complete. For example, if someone stands immediately adjacent to the center of the test area while the gauge is being zeroed out, then moves away from that area before the test is complete, the deflection gauge reading may be unrealistically high ... "

For example, a concern is movement on lightweight (steel) roof decks. Any rooftop movement from the joist space where the test chamber is located to an adjacent joist space significantly can affect measured roof system deflection within the test chamber.

ASTM E907 and FM 1-52 indicate field-uplift testing only should be conducted when roof surface temperatures are between 40 F and 110 F. ASTM E907 also indicates testing should not be conducted when roof level wind speeds are in excess of 15 mph. Testing outside these parameters can affect results.

ASTM E907 includes specific requirements for reporting test results, including providing the test locations on a roof plan drawing; a detailed description of the roof assembly; documentation of air and roof surface temperatures and internal building pressures; a description of the test procedure and maximum applied pressures; a tabulation of results; and documentation of any test cuts. It also references ASTM Practice E575, "Practice for Reporting Data from Structural Tests of Building Constructions, Elements, Connections, and Assemblies," as a basis for reporting.

FM 1-52 provides minimal guidance for reporting results other than the results should be reported on FM Global Form X2688, "Application for Acceptance of Roofing Systems." This form simply requires an indication whether uplift testing was successful; notation of the test pressures in the field, perimeter and corners; and an explanation why the testing wasn't successful. Clearly, FM 1-52's minimal reporting requirements do not provide FM Global with enough information to determine whether FM 1-52 testing is conducted properly and whether the results truly are representative.

NRCA's experience

NRCA has conducted and witnessed hundreds of ASTM E907 and FM 1-52 negative-pressure tests dating as far back as the 1980s. It also has reviewed a large number of field-uplift reports from tests conducted by others. On this basis, it is clear a large percentage—in fact, a large majority—of the tests NRCA has observed or reviewed has not been conducted in strict accordance with ASTM E907 or FM 1-52.

Testing in excess of the design-uplift pressure or FM 1-52's test pressure of 1.25 times the design-uplift pressure is commonplace. Also, in too many instances, the described considerations that can affect test results' reliability have not been taken into consideration. Either of these situations can and have resulted in individual tests and sometimes complete roof systems being determined as failures when they should have been considered as passing.

Also, no correlation has been established between the results of field-uplift testing and laboratory testing, such as testing conducted by FM Approvals, for determining roof systems' design uplift resistances (FM 1-60, FM 1-90, FM 1-120, etc.).

In 2008, NRCA conducted a survey regarding NRCA member experiences with FM Global's guidelines and field-uplift tests. It received reports for more than 8,000 roofing products. FM Global's guidelines were reported to be specified in about 26 percent of those projects, yet FM Global was reported to be the property insurer only in about 3 percent of the projects. Field-uplift testing was reported to be conducted only in about 1 percent of the projects reported. Only about 55 percent of the projects conducted with field-uplift testing had passing results.

If only 55 percent of the projects in NRCA's survey have field-test results matching FM Global's laboratory test results, clearly there is minimal to no correlation between FM 1-52 (and ASTM E907) testing and FM Global's laboratory testing. Inaccurate (non-repeatable) laboratory tests, laboratory test specimens not being representative of actual field installations or variability in field test methods are probable reasons for this lack of correlation, as well as other likely reasons.

NRCA's recommendations

Because of the known variability in test results using ASTM E907 and FM 1-52, and the lack of correlation between laboratory uplift-resistance testing and field-uplift testing, NRCA considers field-uplift testing to be inappropriate for use as a post-installation quality assurance measure for membrane roof systems.

NRCA maintains the best, most reliable means of assessing the quality of a newly installed roof system is through continuous observation of the application by a knowledgeable roofing professional at the time of installation.

NRCA's publications *Quality Control Guidelines for the Application of Built-up Roofing*; *Quality Control Guidelines for the Application of Polymer-modified Bitumen Roofing*; and *Quality Control Guidelines for the Application of Thermoset Single-ply Roof Membranes* contain detailed guidelines for quality control and quality assurance assessments of membrane roof system applications. Two additional NRCA publications, *Quality Control Guidelines for the Application of Asphalt Shingle Roof Systems* and *Quality Control Guidelines for the Application of Spray Polyurethane Foam-based Roofing*, address asphalt shingle and SPF roof systems, respectively. These documents are available by accessing shop.nrca.net.

NRCA encourages roofing contractors and manufacturers to consider avoiding projects where field-uplift testing is indicated in the contract documents as a basis for acceptance of roofing work. A roof system's ability to pass wind-uplift tests and meet designated

uplift pressures depends on numerous factors—a roofing contractor's installation of the materials is one factor.

The National Roofing Legal Resource Center (NRLRC) suggests the following language be added to proposals and contracts for roofing projects where compliance with FM Global's guidelines are or may be required: "To the extent specifications call for the roof assembly to meet particular wind loads or uplift pressures,

Roofing Contractor relies upon the Design Professional to specify appropriate materials and components, including deck construction, that will obtain the desired wind-uplift capacity. If the Owner has not retained a Design Professional to prepare specifications identifying the roof materials and methods of construction, Roofing Contractor will install insulation and membrane materials in a good and workmanlike manner that have been listed either by FM Global, the membrane manufacturer or others as having been tested under laboratory conditions and reported

to have met the designated load and uplift pressures. Roofing Contractor itself makes no representation regarding wind-uplift resistance and whether the roof assembly will meet a wind-uplift test. Roofing Contractor's obligation is to install the prescribed materials in a good and workmanlike manner in accordance with the project designer's specifications or, if there is no project designer, the membrane manufacturer's printed installation instructions."

NRLRC also recommends the following statement be added at the end of a contract's payment clause: "Roofing Contractor's entitlement to payment is not dependent upon meeting criteria promulgated by FM Global, including wind-uplift testing."

In situations where field-uplift testing is being conducted but has not specifically been called for in contract documents, roofing contractors should go on record using NRCA's concerns regarding field-uplift testing, such as sharing a copy of this document with pertinent parties, and stipulate entitlement to payment is not dependent upon successful wind-uplift testing. NRLRC's contract provision language (previously stated) also can be adapted for this purpose.

NRCA roofing contractor members are encouraged to contact NRLRC at (847) 299-9092 or via email at nrlrc@nrlrc.net to address any questions regarding NRLRC's suggested contract provision language.

NRCA also encourages members to share their field-uplift testing experiences and direct any questions regarding field-uplift testing to NRCA's Technical Services Section at (800) 323-9545.

NRCA encourages
roofing contractors to
consider avoiding projects
where field-uplift testing
is indicated in contract
documents as a basis for
acceptance of roofing work

Mark S. Graham is NRCA's vice president of technical services.

