

Step 1.1 Install Eave Trim on Lower Roof Deck.

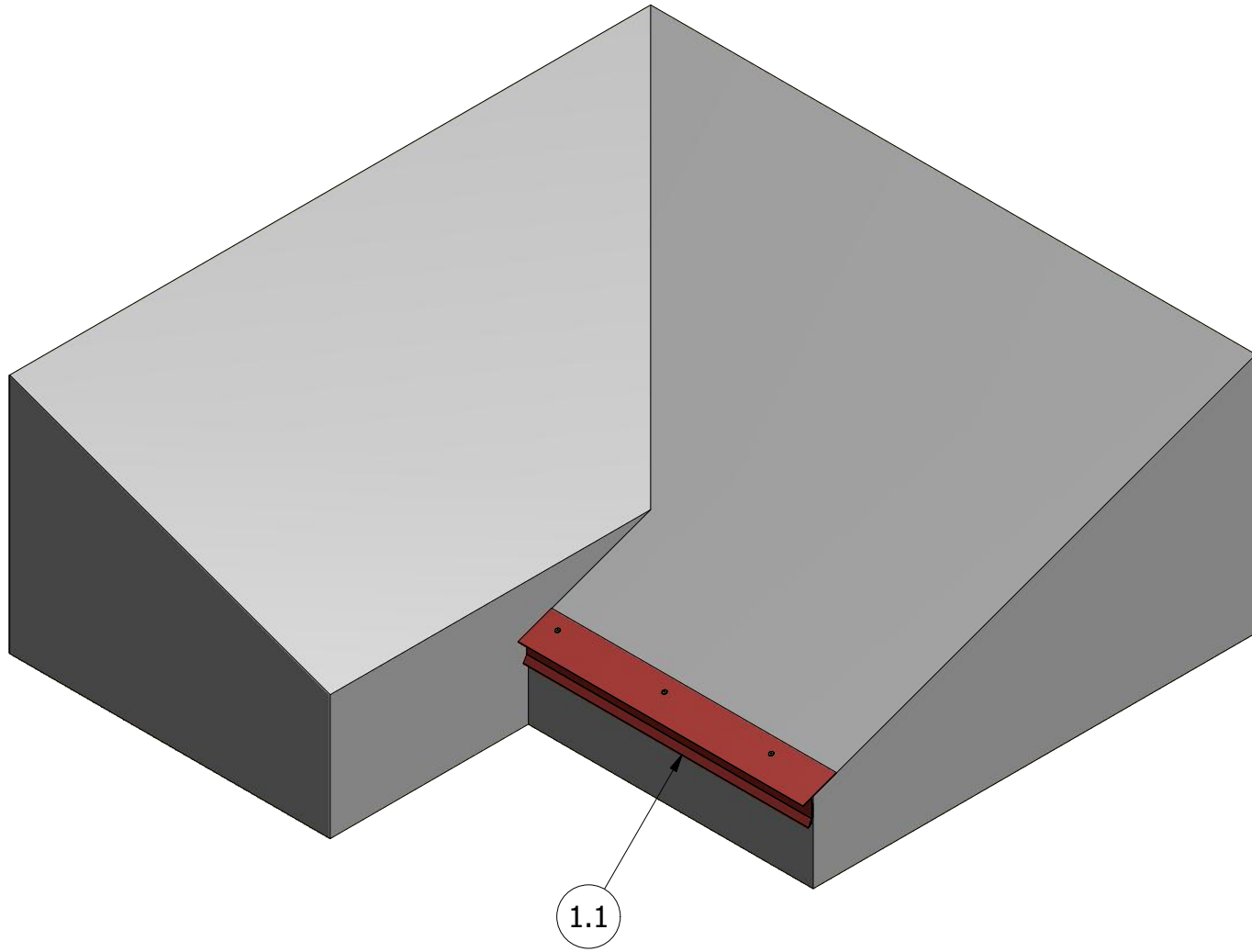
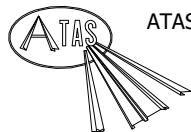

	ATAS INTERNATIONAL, INC Allentown PA 610-395-8445 Mesa AZ 480-558-7210	
	TITLE NRCA Valley Installation Detail	
DWG. NO.	DR KRK	DATE 10/4/2022
MATERIAL	APP	DATE
REV. NO.	DATE	DESCRIPTION OF REVISION
BY	APP	
	SH. SIZE A	SCALE X:X

REV. NO.	DATE	DESCRIPTION OF REVISION	BY	APP

- Step 2.1 Field Trim and Form Roof Panel up on Upper Roof Deck as Shown.
- Step 2.2 Trim Roof Panel as Shown to prepare for Panel Overlap.
- Step 2.3 Install Joggle Cleat on top of Butyl Sealant Tape with Appropriate Screws.

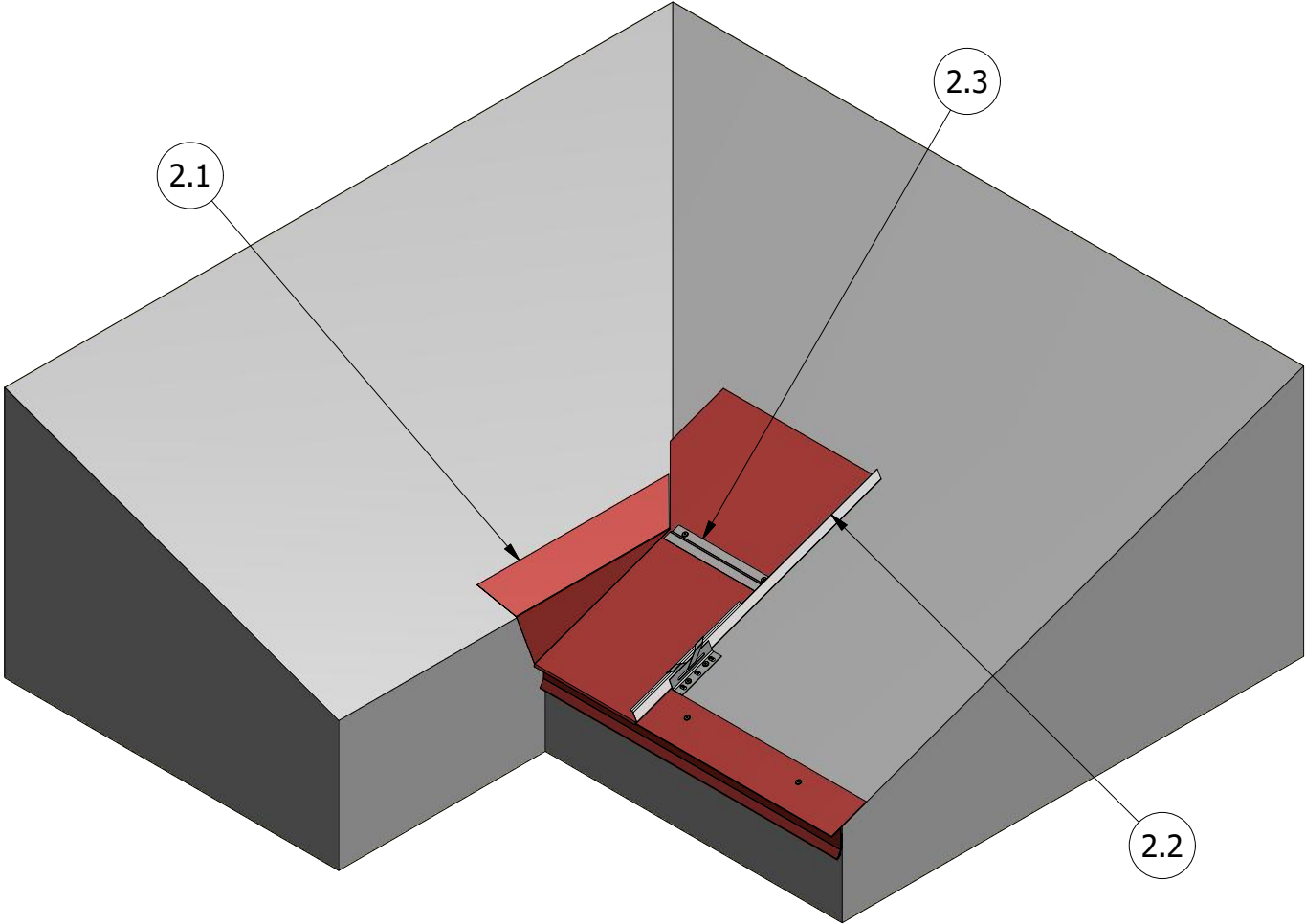

ATAS INTERNATIONAL, INC
 Allentown PA
 610-395-8445
 Mesa AZ
 480-558-7210

TITLE		NRCA Valley Installation Detail	
DWG. NO.	DR	KRK	DATE
	APP		DATE
MATERIAL	SH. SIZE	A	SCALE
			X:X

REV. NO.	DATE	DESCRIPTION OF REVISION	BY	APP

Step 3.1 Install Eave Trim on Upper Roof Deck as shown.
 Step 3.2 Field Notch Eave Trim as Required.

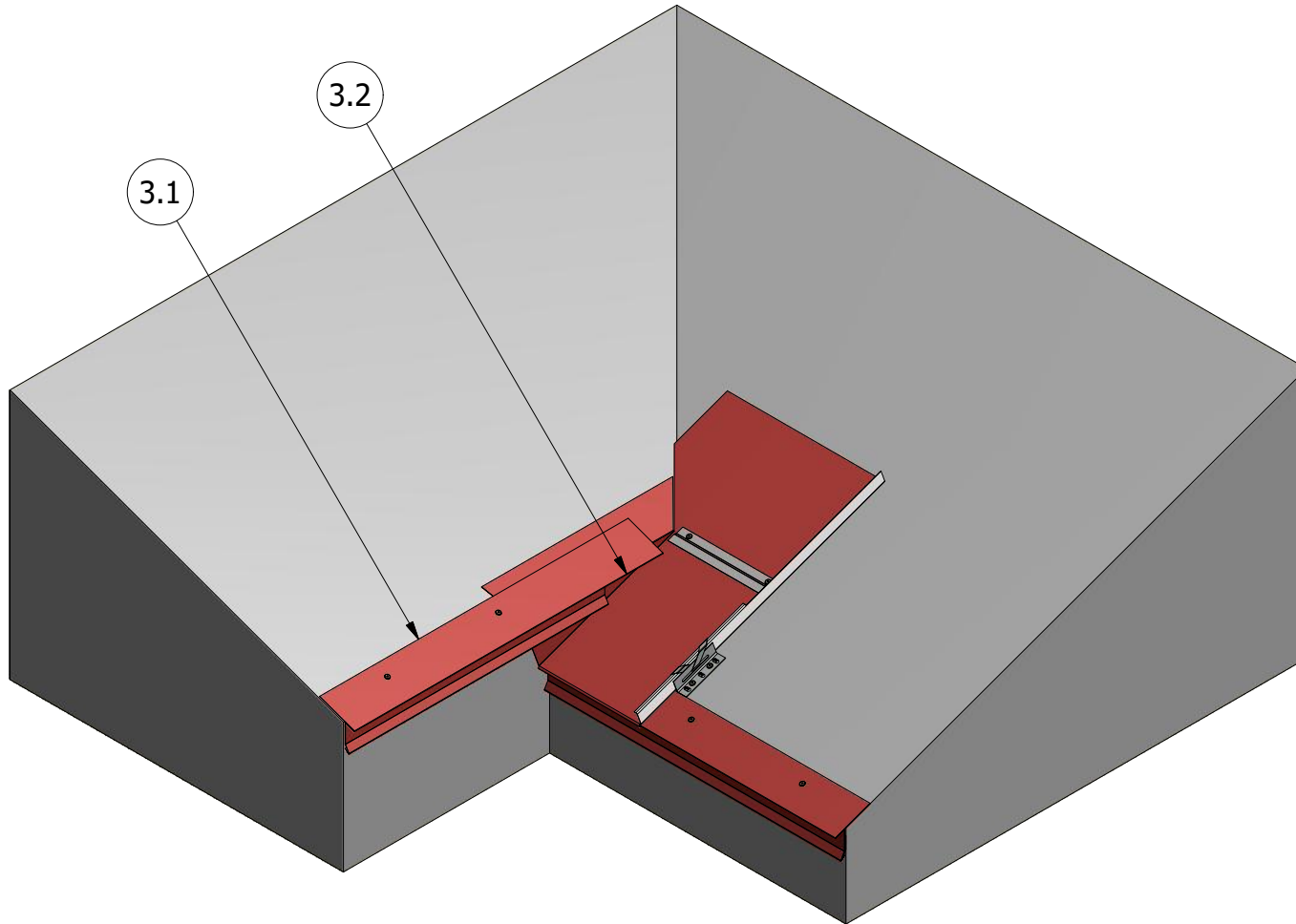



ATAS INTERNATIONAL, INC
 Allentown PA
 610-395-8445
 Mesa AZ
 480-558-7210

TITLE **NRCA Valley Installation Detail**

					DWG. NO.	DR	KRK	DATE	10/4/2022
					MATERIAL	APP		DATE	
REV. NO.	DATE	DESCRIPTION OF REVISION	BY	APP		SH. SIZE	A	SCALE	X:X

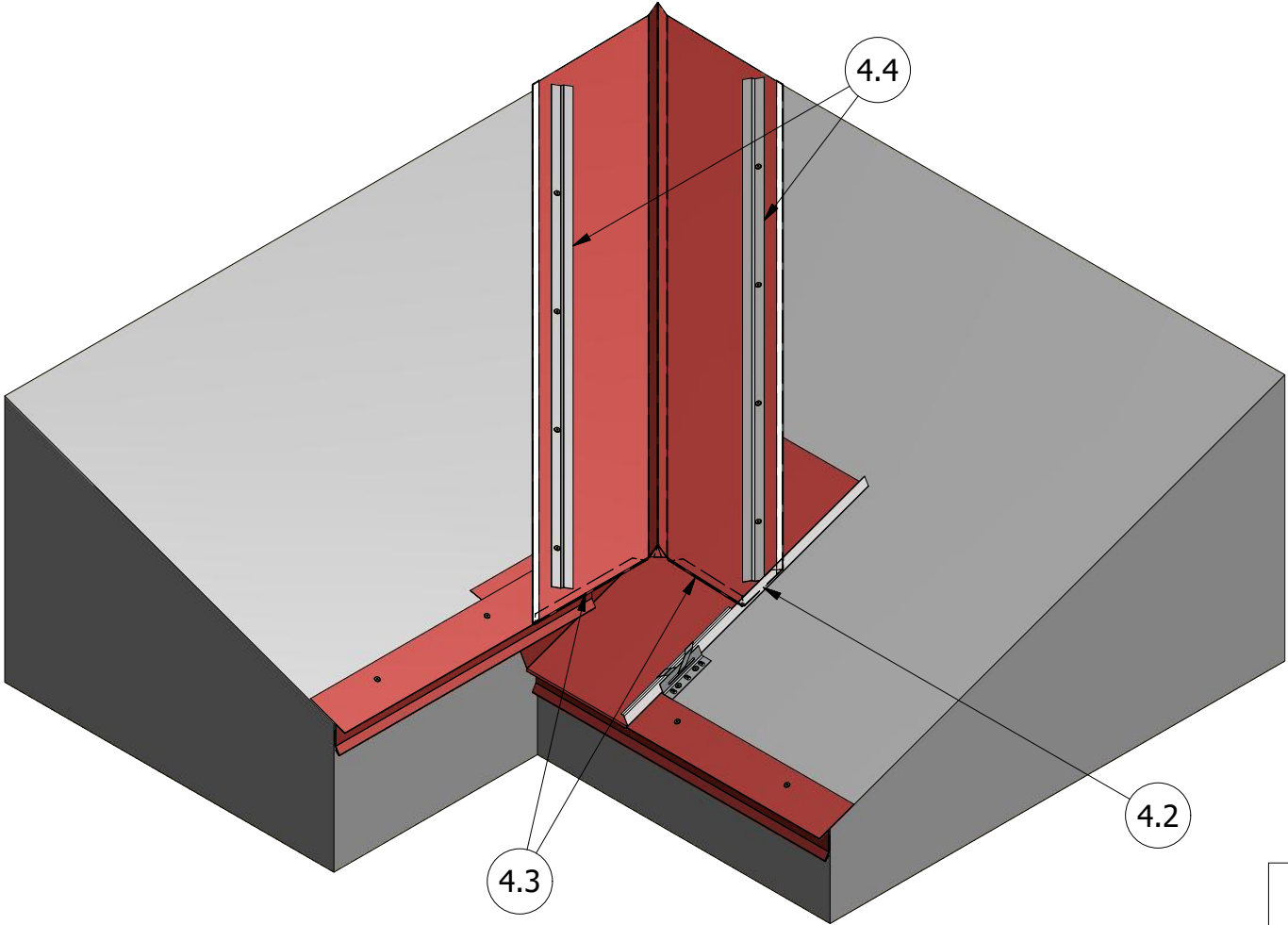
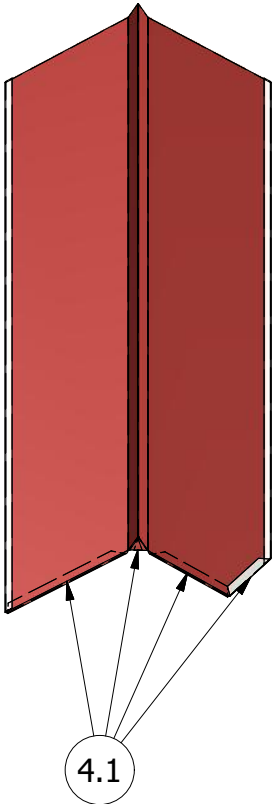
- Step 4.1 Field Trim and Fold Valley Trim as Shown.
- Step 4.2 Trim and Fold Valley Trim up into Panel Seam.
- Step 4.3 Install Valley Trim onto Joggle Cleats.
- Step 4.4 Install Joggle Cleats on top of Butyl Sealant Tape with Appropriate Screws.



		ATAS INTERNATIONAL, INC Allentown PA 610-395-8445 Mesa AZ 480-558-7210	
		TITLE NRCA Valley Installation Detail	
DWG. NO.		DR KRK	DATE 10/4/2022
MATERIAL		APP	DATE
REV. NO.	DATE	DESCRIPTION OF REVISION	BY APP
SH. SIZE A		SCALE X:X	

REV. NO.	DATE	DESCRIPTION OF REVISION	BY	APP

Step 5.1 Install Roof Panel on Roof and Hem Panel around Eave Trim.

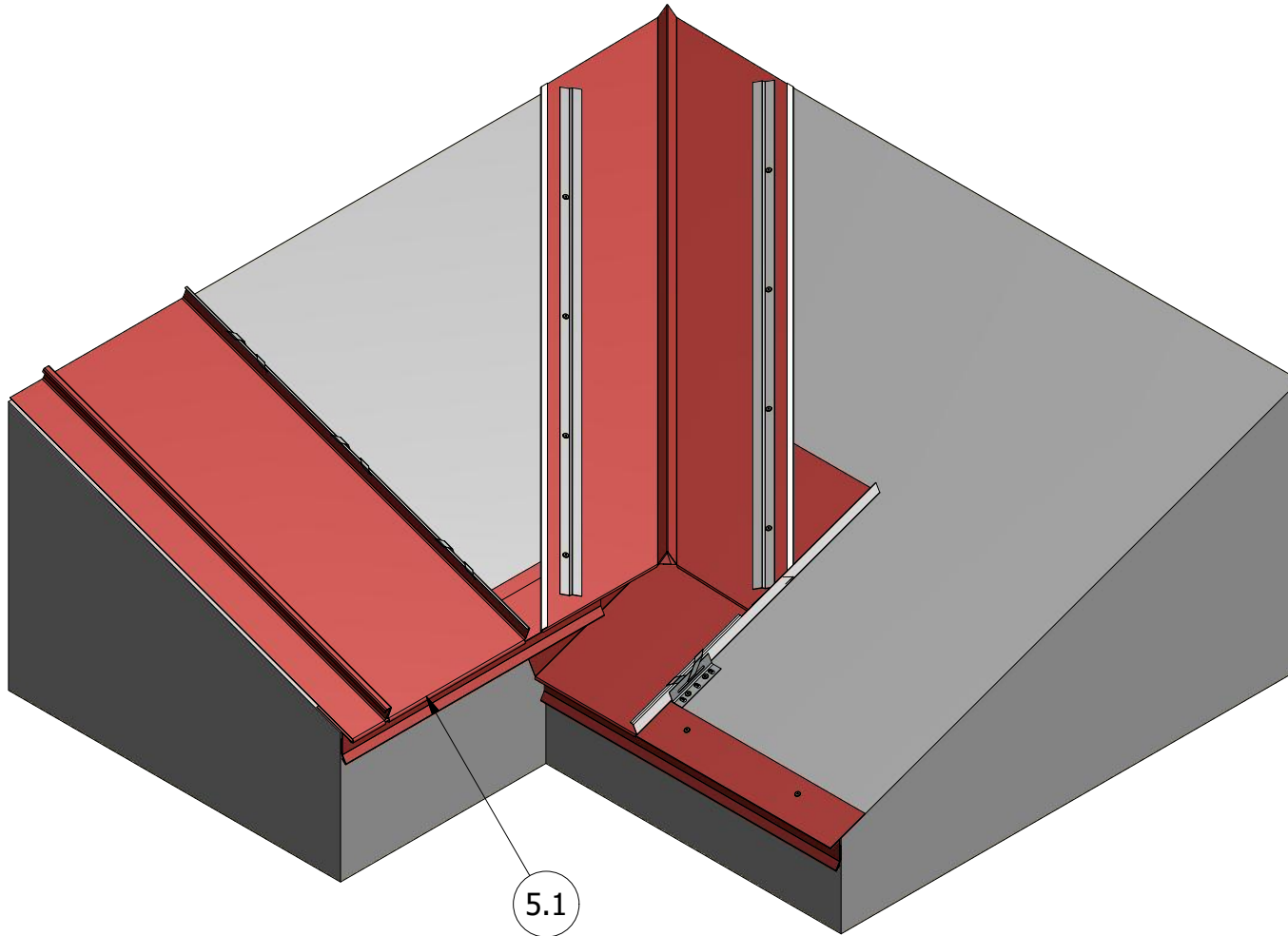

5.1



ATAS INTERNATIONAL, INC
 Allentown PA
 610-395-8445
 Mesa AZ
 480-558-7210

TITLE **NRCA Valley Installation Detail**

REV. NO.	DATE	DESCRIPTION OF REVISION	BY	APP

DWG. NO.	DR	DATE
	KRK	10/4/2022
MATERIAL	APP	DATE
	SH. SIZE	SCALE
	A	X:X

Step 6.1 Install Roof Panel on Roof working into the Valley.
 Step 6.2 Field Trim and Fold Panels around Joggle Cleat on Valley Trim.

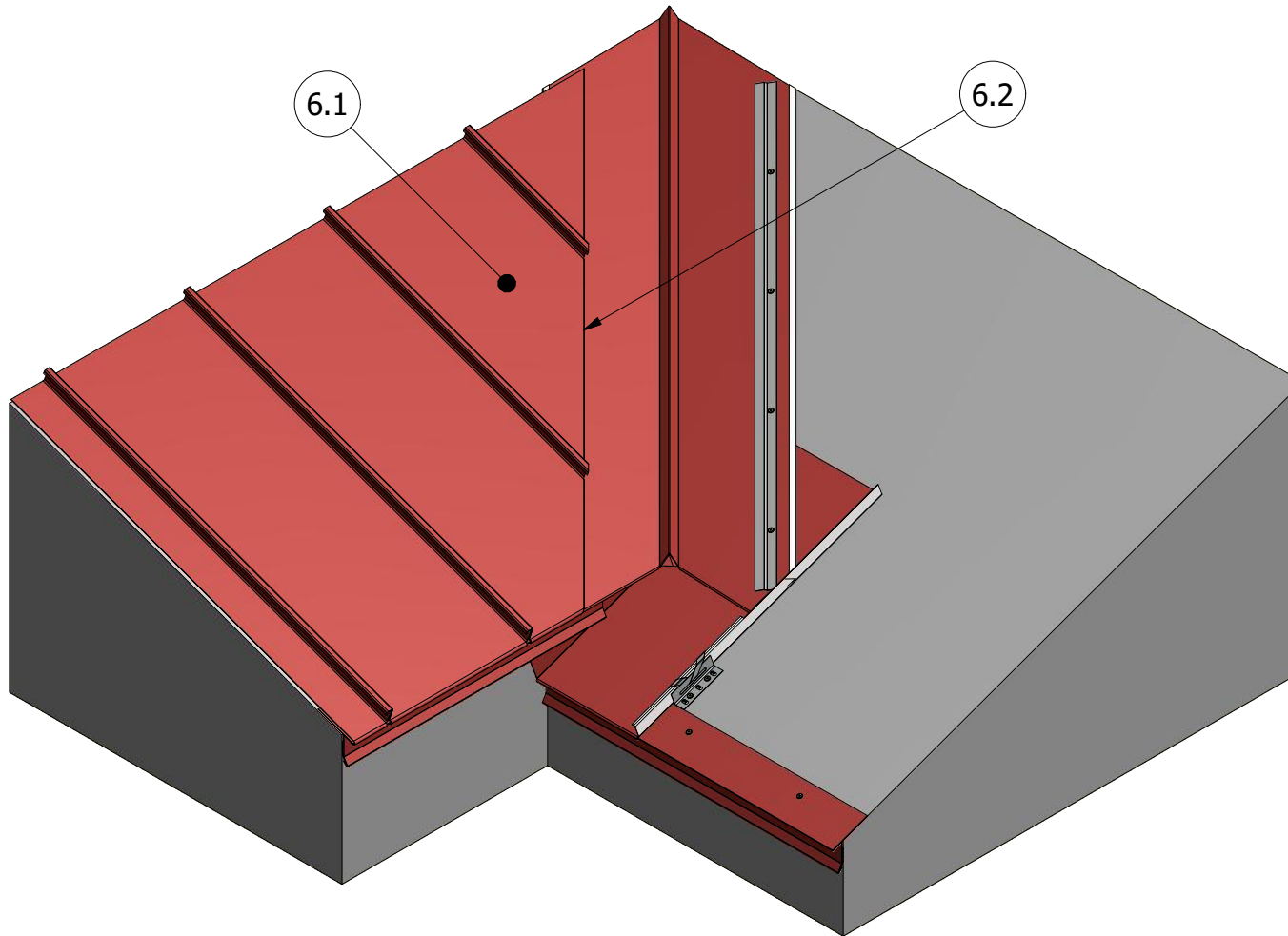

ATAS INTERNATIONAL, INC
 Allentown PA
 610-395-8445
 Mesa AZ
 480-558-7210

TITLE **NRCA Valley Installation Detail**

REV. NO.	DATE	DESCRIPTION OF REVISION	BY	APP

DWG. NO.	DR	DATE
	KRK	10/4/2022
MATERIAL	APP	DATE
	SH. SIZE	SCALE
	A	X:X

Step 7.1 Repeat Step 6 on other side of Valley Trim as Shown.

Step 7 of 8

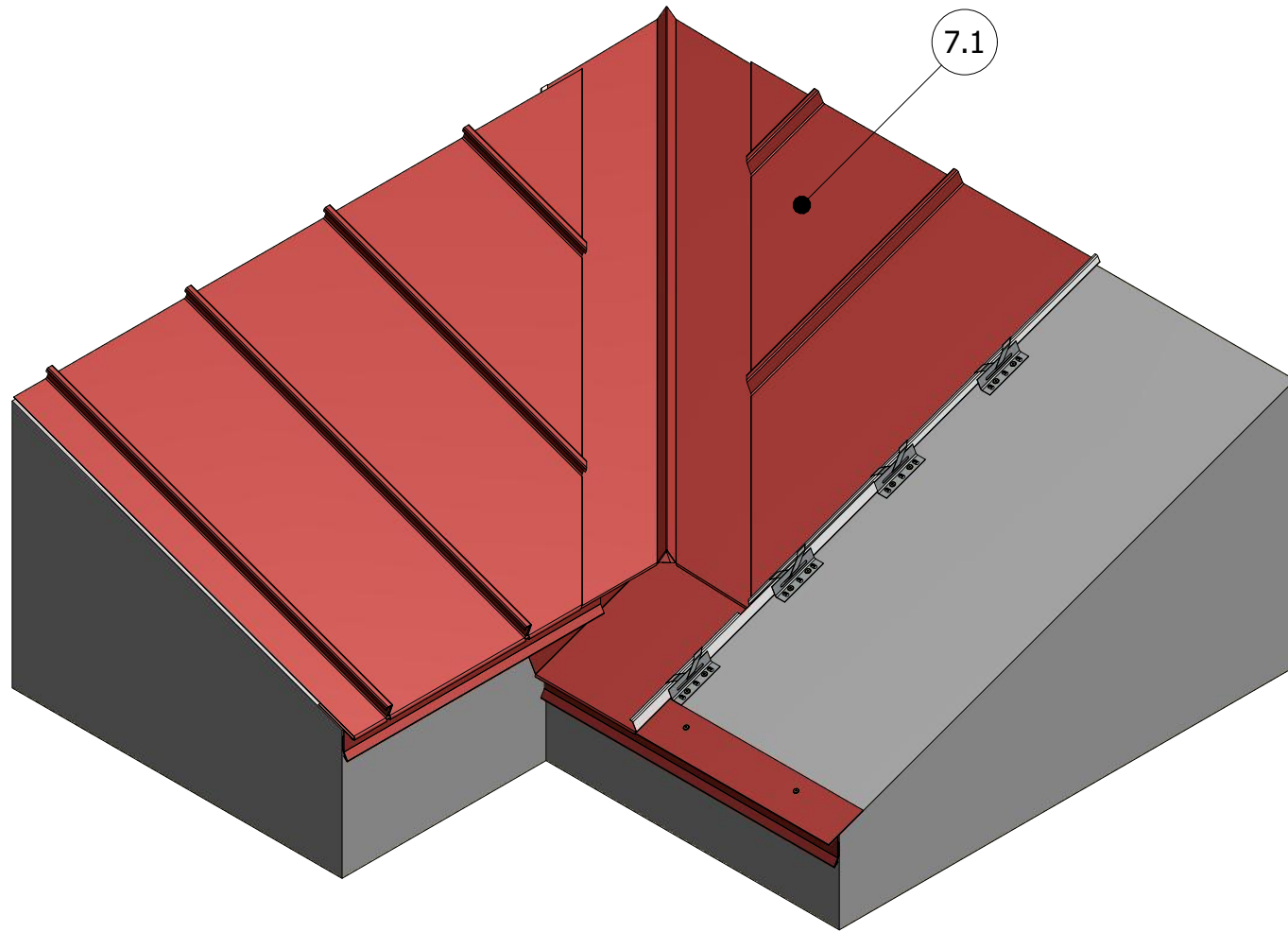

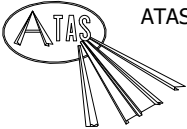
	ATAS INTERNATIONAL, INC Allentown PA 610-395-8445 Mesa AZ 480-558-7210		
	TITLE NRCA Valley Installation Detail		
DWG. NO.	DR	APP	DATE
	KRK		10/4/2022
MATERIAL	SH. SIZE	SCALE	
	A	X:X	

REV. NO.	DATE	DESCRIPTION OF REVISION	BY	APP

Step 8.1 Continue Panel Installation as Normal.

Step 8 of 8

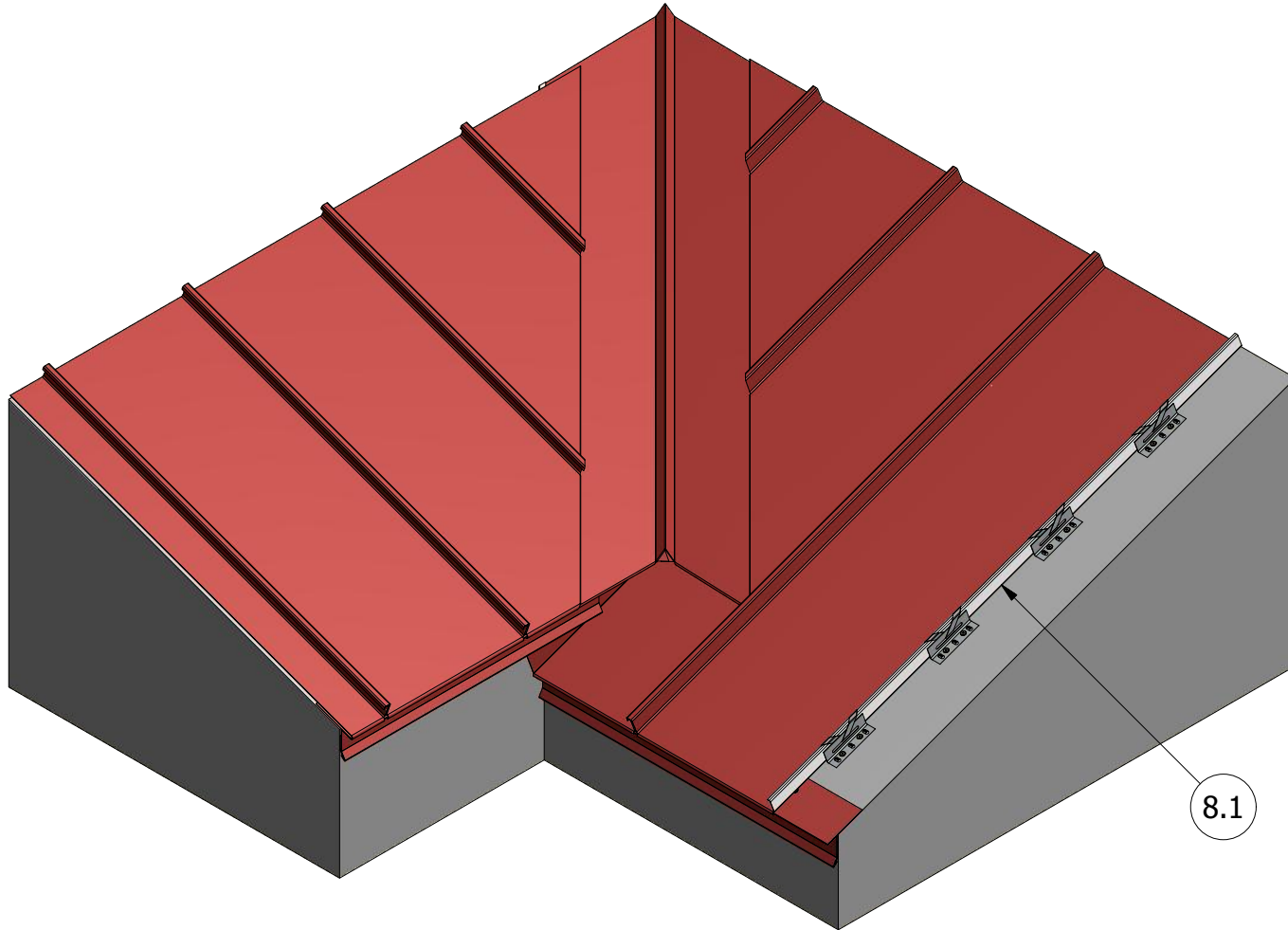

8.1



ATAS INTERNATIONAL, INC
 Allentown PA
 610-395-8445
 Mesa AZ
 480-558-7210

TITLE **NRCA Valley Installation Detail**

REV. NO.	DATE	DESCRIPTION OF REVISION	BY	APP

DWG. NO.	DR	DATE
	KRK	10/4/2022
MATERIAL	APP	DATE
	SH. SIZE	SCALE
	A	X:X

